	MATERIAL Steel Sheet cool rolled		
	FINISHED Electrostatic Painting black		
	COD. CBC-0180	UNID. UR 1	CAPACITY KG. 20

Dimension

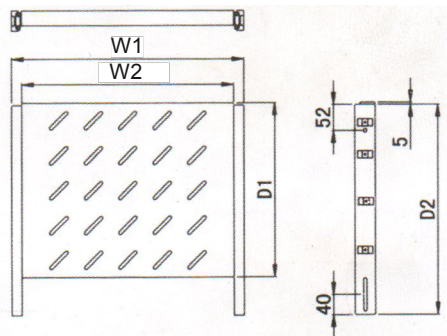

D1=500mm
D2=550mm
W1=425mm
W2=465mm

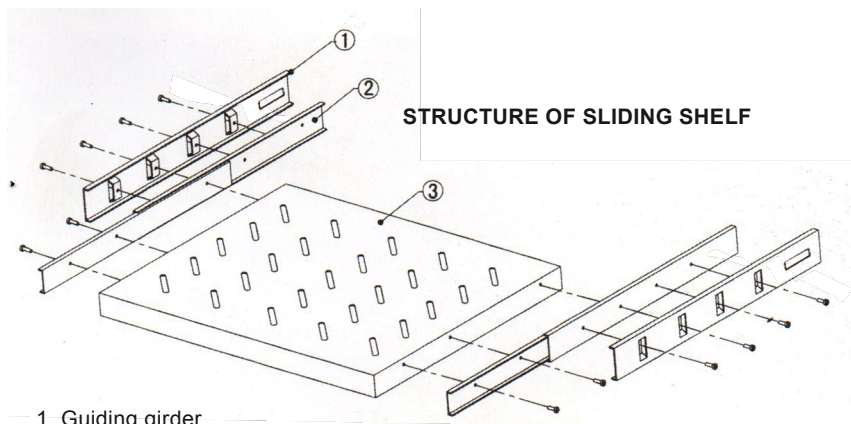

- 1. Guiding girder
- 2. 14" 2-section sliding rail
- 3. Sliding loading plate

SLIDING SHELF

MATERIAL:

SPCC cold rolled steel t1.2/14" 2-section slide

SURFACE FINISH

Degreasing, pickling, phosphoric, powder coated

PARAMETER:

Flexing length: 300mm loading capacity: 20Kg